

# DRYCONN®

## WATERPROOF CONNECTIONS

### Anode Splice Box



## Installation Instructions

1. Install electrical connection per connector manufacturer's instructions.
2. Lay main conductor into conductor cradles centering electrical connector as shown in Figure A.
3. Position Tap conductor as shown in Figure A. Note: Tap conductor can be positioned to exit either side of housing.
4. Install wire ties tightly around main conductor. Cut remaining length of wire tie and discard.
5. Close housing verifying it is securely latched.

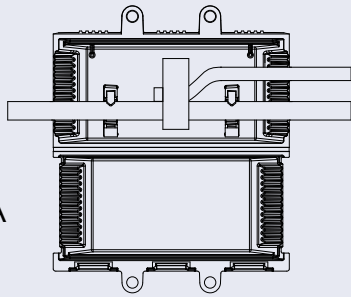

Figure A

#### Important Notice:

All of the statements, technical information, drawings, illustrations, and instructions related to King Innovation's products are based on information understood as reliable and correct to the best of the company's knowledge. Prior to product usage, independent evaluation is recommended to evaluate and determine if it is suitable for the proposed application. All risks and liability are assumed by the independent user. Any assertion associated to the product which is not outlined in King Innovation's current publications, or any dissimilar assertion contained on individual purchase orders shall have no force or effect unless explicitly arranged, in writing, by an authorized officer of King Innovation. King Innovation's liability for these products is set forth in our standard terms and conditions of sale. King Innovation is a registered trademark.

## DryConn® VisiLock® with SmartGel®

Catalog #	Selling Unit	Case Pack
98010	1 pc box	12

## Product Specifications and Measurements

Max. Voltage: 100V

Temperature Rating: -40° - 90°C (194°F)

Wire Range: Main: #8 - 1/0 (.363" - .625" O.D.)

Tap: #12 - #4 (.305" - .443" O.D.)

### Measurements (Inches/Centimeters)

A - 1.75/4.45 B - 3.35/8.51 C - 0.98/2.49

D - 5.50/13.97 E - 0.25/ 0.64 F - 6.69 /16.99

G - 1.81/4.60

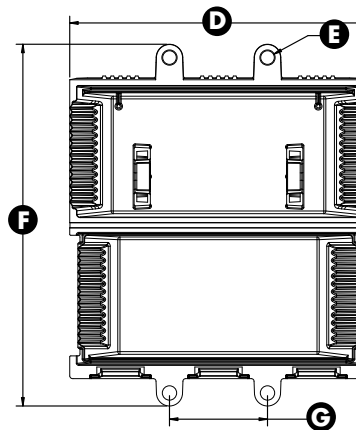
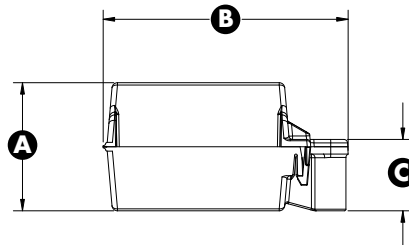

## DryConn® VisiLock® with SmartGel®



### Features and Benefits

- Waterproof and corrosion proof
- Pre-filled with a non-toxic gel that eliminates hazmat requirements
- Re-enterable, semi-transparent, encapsulated splice box allows for visible splice examination
- Includes mounting tabs to securely attach housing to structures
- Locking mechanism centers splice in box
- One piece for fast, easy installation
- No need to abrade cable during installation
- No assembly or set-up time required
- No shelf life issues with SmartGel
- Eliminates heat shrinks, primers, tapes, and epoxy packs
- Amperage not to exceed maximum temperature of the conductor
- Designed to protect cathodic splices from corrosion
- For use in outdoor or direct-burial locations
- For making tap or branch splices on insulated cables rated up to 100V

### Eliminate these time-consuming steps:

- Two-part epoxy mixing and messy pouring methods
- Ambient temperature issues with epoxy splice methods
- Assembly and set-up time
- Hazmat requirements with transporting materials
- Heat shrinks, primers, tapes, and epoxy packs

### Product Data and Testing Information:

- Gel is a cross-linked silicone polymer
- Tests Conducted:
  1. 500 Hour Salt Fog
  2. Immersion / Heating / Cooling Sequence:
    - 24 hour water immersion → 72 hours at 75°C → 24 hours water immersion
    - 4 hours at → -18°C → 24 hours water immersion
  3. 336 hours of immersion in 10% chlorine solution
  4. 336 hours of immersion in 5% salt water solution
  5. 30 minute water submersion at 6 feet followed by dielectric at 1000VAC
  6. Impact at ambient and following 168 hours at 110°C. 4 hour water immersion following impact.

#### NOTE:

1. The above tests were conducted with separate sets of samples.
2. Dielectric at 1,000VAC and Insulation Resistance at 250VDC conducted following all 24 hour immersions, chlorine and salt water immersion and impact testing.

U.S. Patent 7,384,297 and 7,431,611. All other trademarks, U.S. and Foreign Patents Pending apply. All Rights Reserved.